

heatwave

Large

dimensions

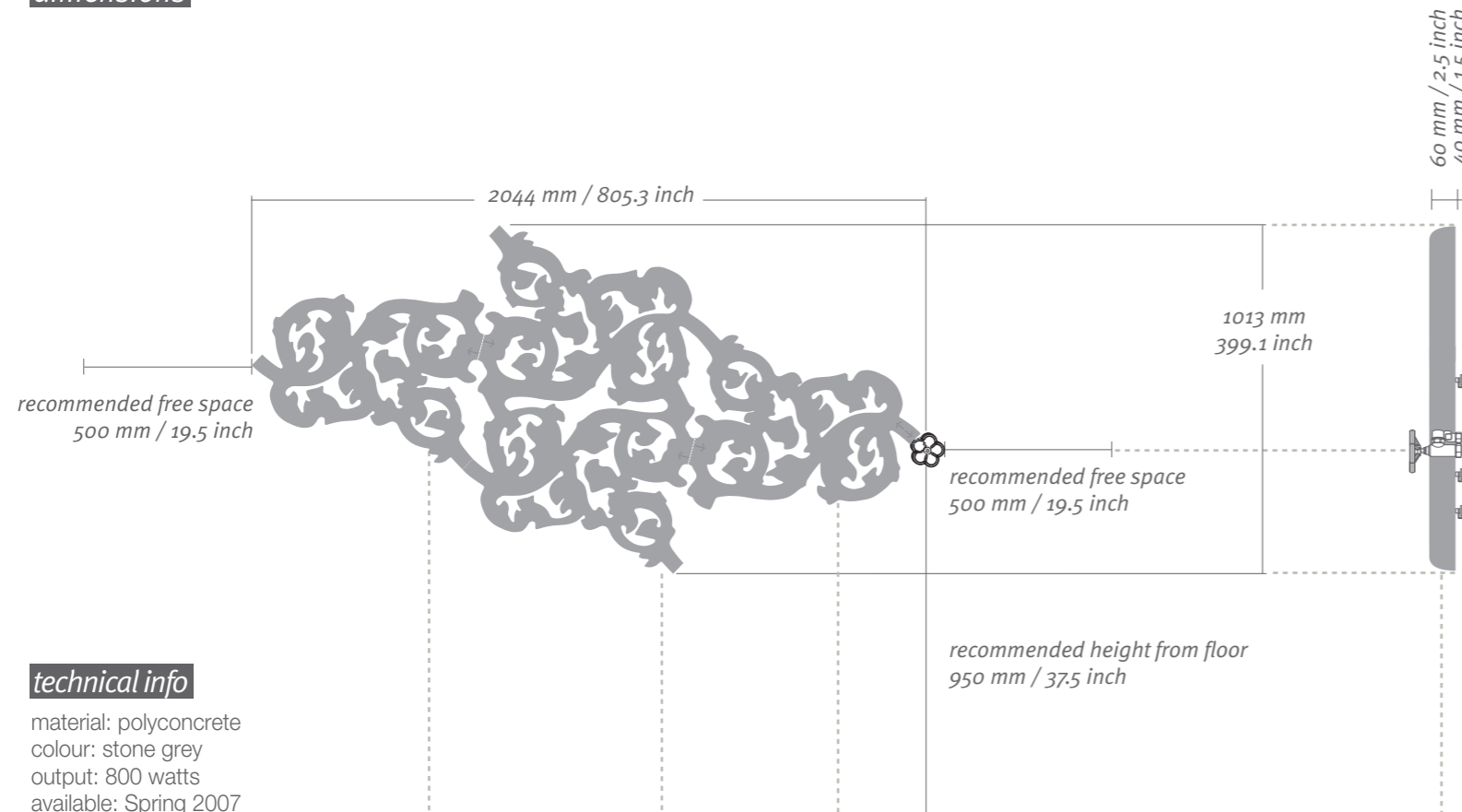

technical info

material: polyconcrete
 colour: stone grey
 output: 800 watts
 available: Spring 2007

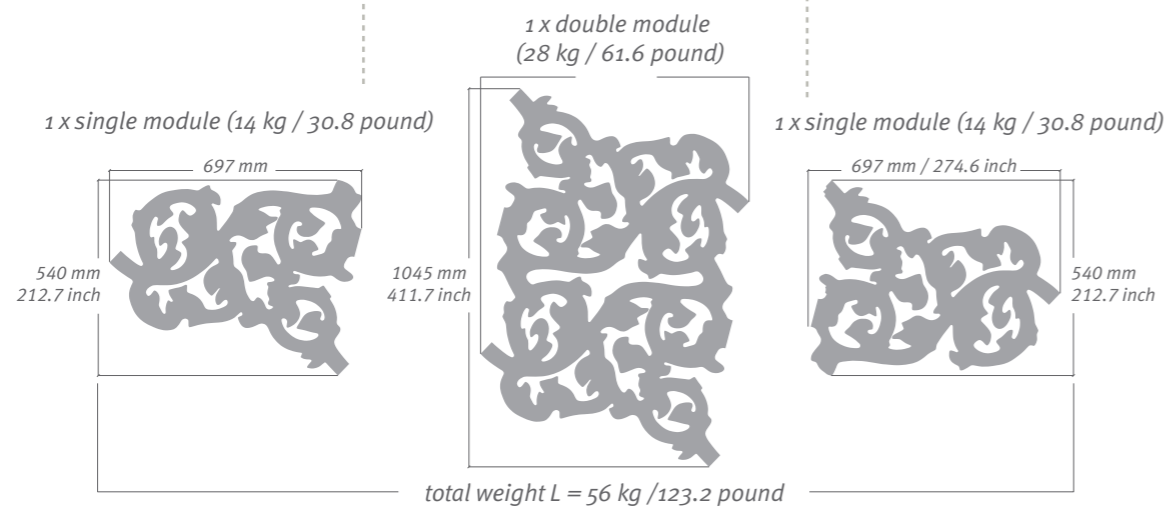

installation

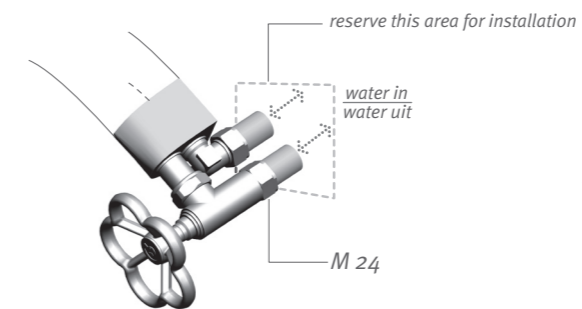

connection to the wall

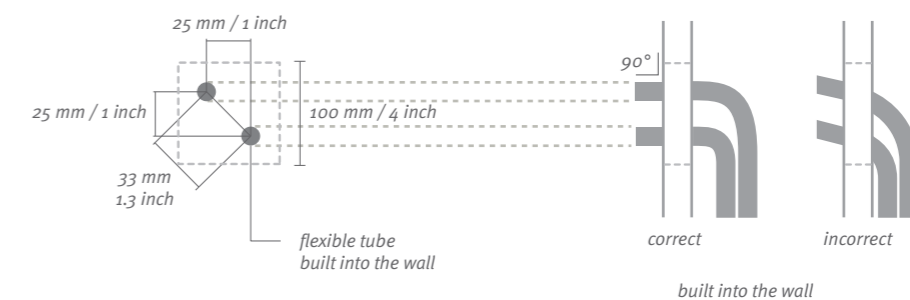
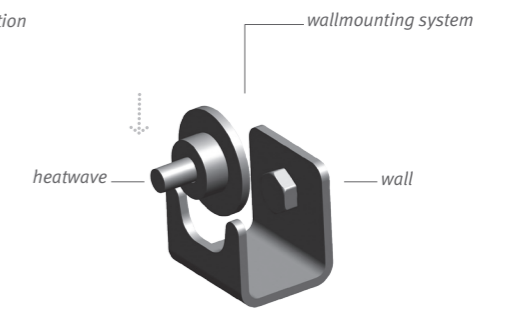

designed by Jaga & Joris Laarman

In principal the 'heatwave' can be seen as a continuously curved tube. Therefore the air is not vented at the appliance itself but in the system. (e.g. boiler, manifold, pipework)